

Road Safety Barriers

We custom manufacture the fully certified LTSA Type E and F family of infrastructure barriers.

Our systemised production ensures total compliance with national standards, consistent quality control, and dependable lead times. From design validation to on-site delivery, we combine precision engineering, systemised fabrication, and strict certification processes to meet the demands of government, roading, and civil infrastructure projects across the country.

Contact our team to discuss project specific requirements, pricing and lead times.



Custom Manufacturing For Cost Effective Specification Compliance

The Gate Group's Hot Dip Galvanised (HDG) railings and barriers are built for durability, strength and safety, making them a preferred choice for bridges and walkways. Manufactured using heavy steel sections that are fully welded and Hot Dip Galvanised, these railings are suited to a wide range of environments. With years of experience, The Gate Group has refined the fabrication of these safety railing systems.

Our walkway and bridge railing systems feature 20mm solid steel rods welded to a heavy-duty steel flat bar and secured to supporting posts. Both the panels and posts are hot dip galvanised to meet Australian/New Zealand Standard AS/NZS 4680:2006, ensuring long-term performance and corrosion resistance.

As well as custom manufacturing to meet specifications, we offer existing designs that comply with the Auckland Transport Code of Practice (ATCOP) for Fence Types E & F.

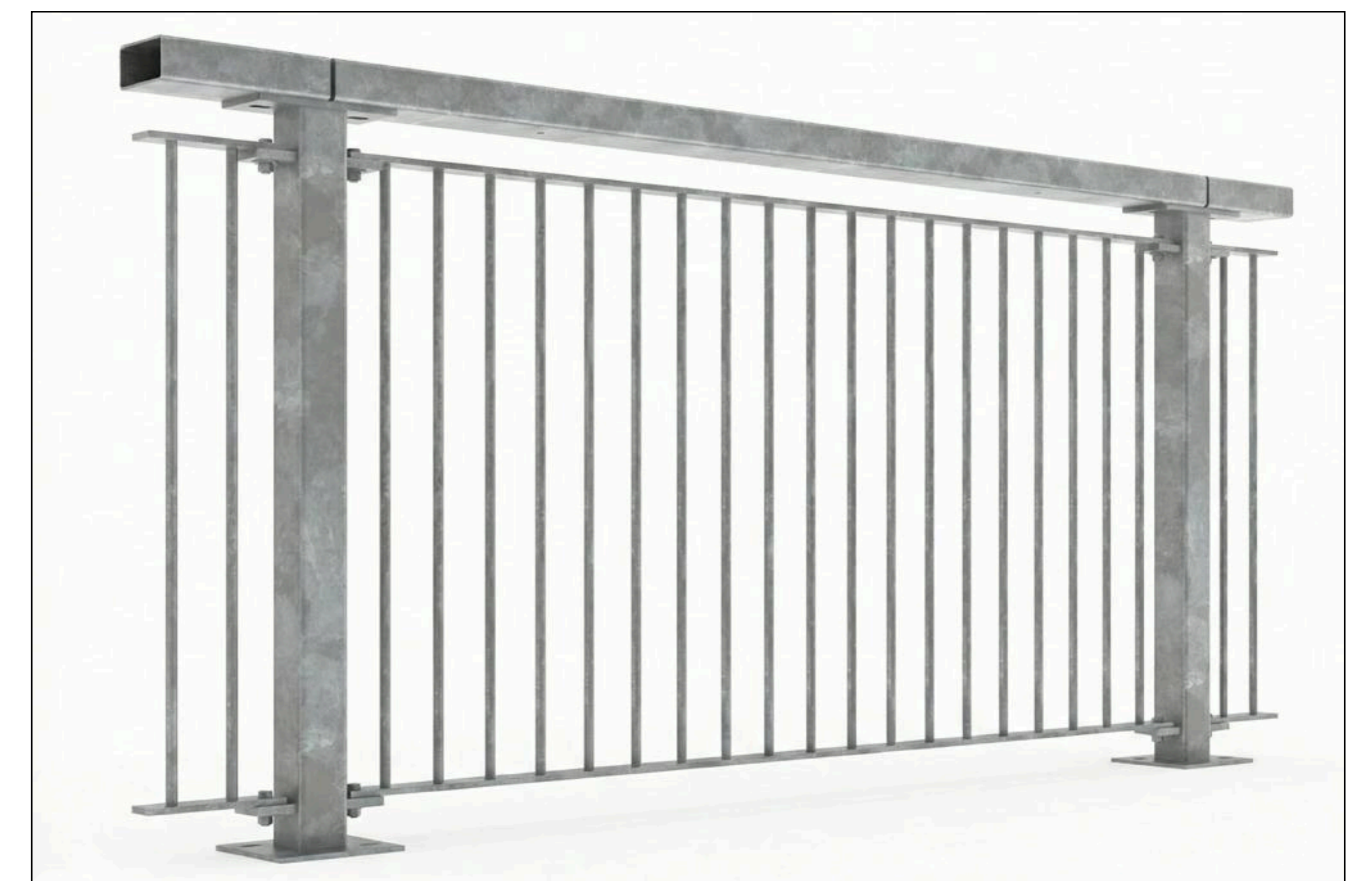
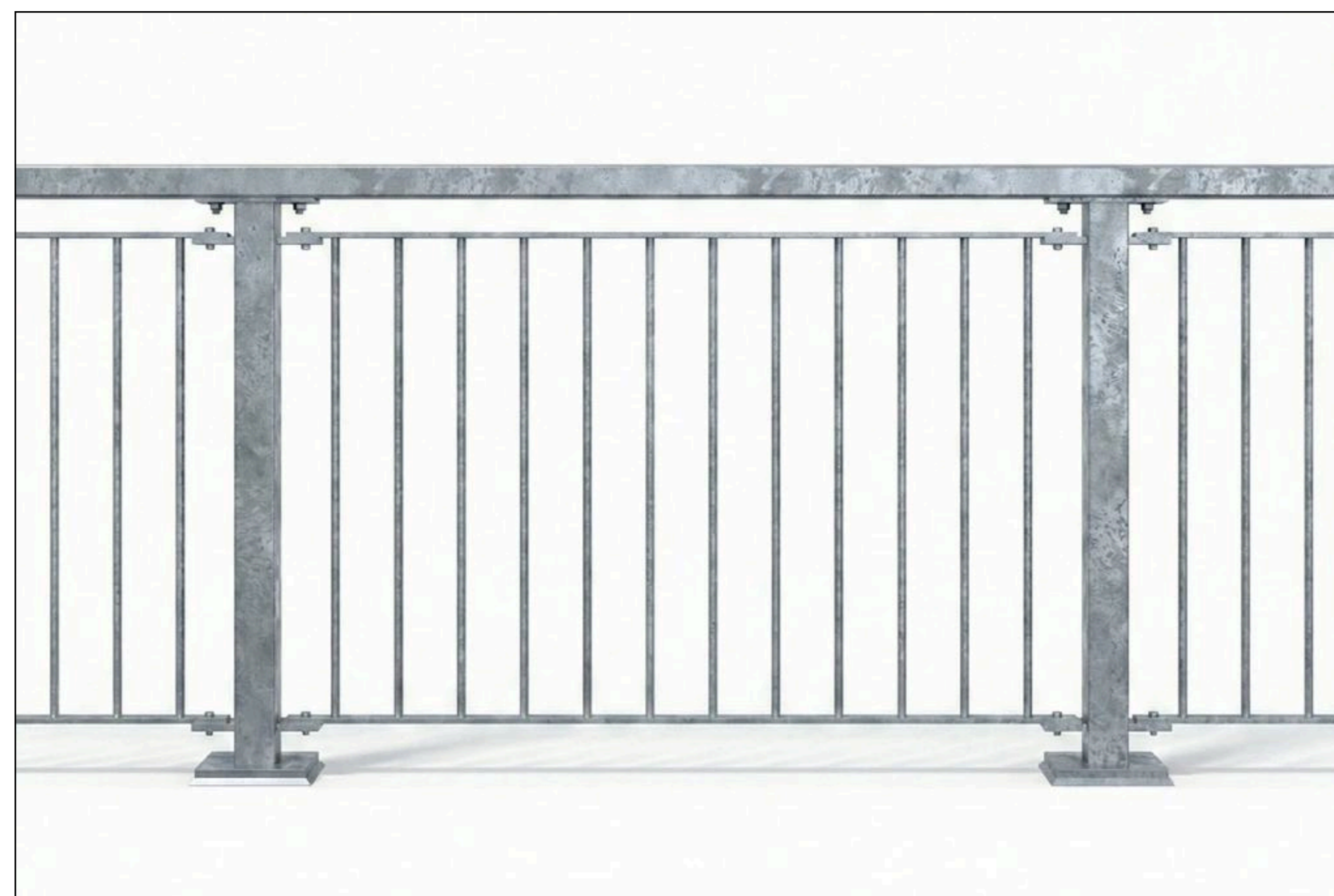

MODEL:
TYPE F FENCE

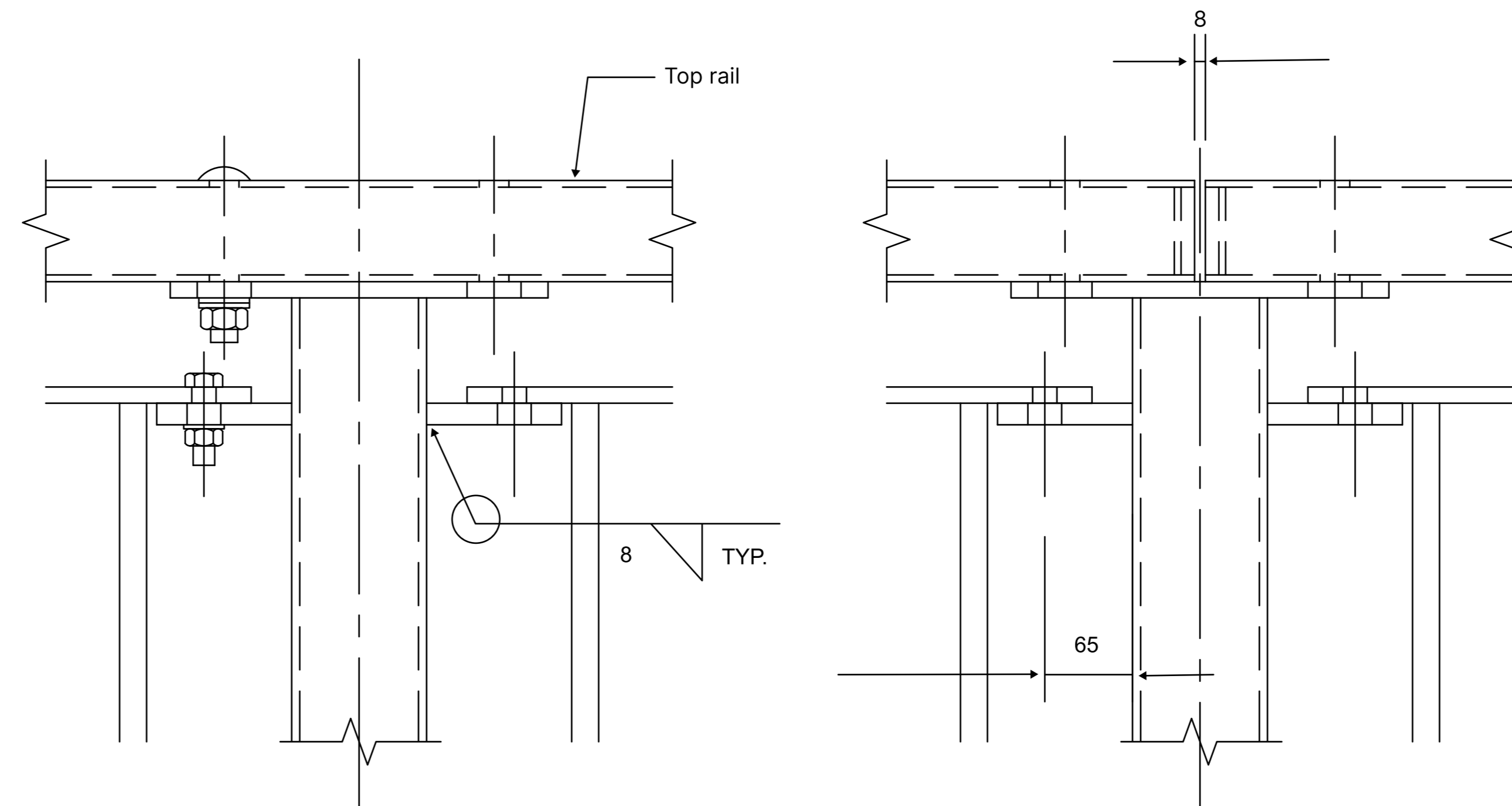
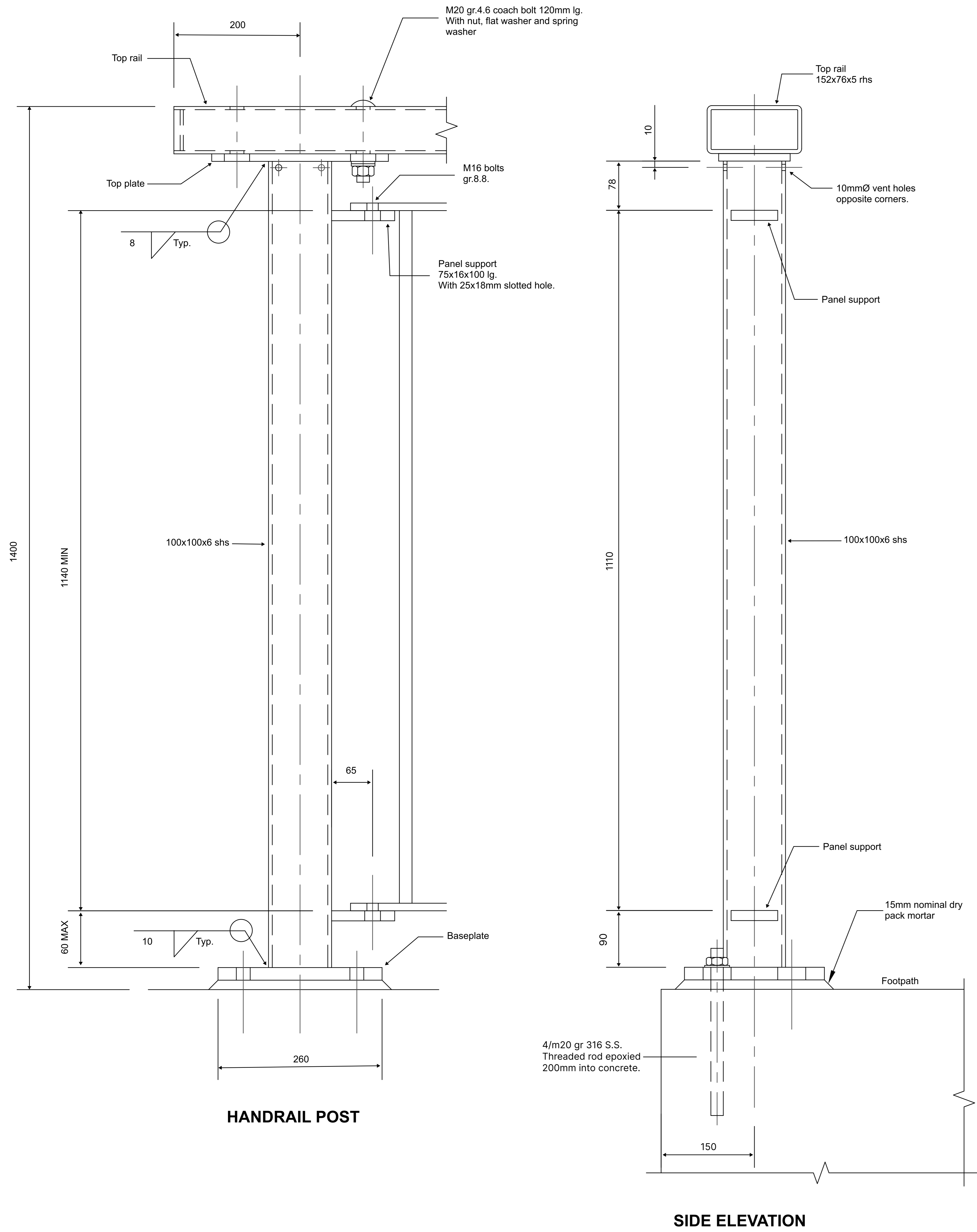

TOP RAIL CONTINUOUS

TOP RAIL JOINT

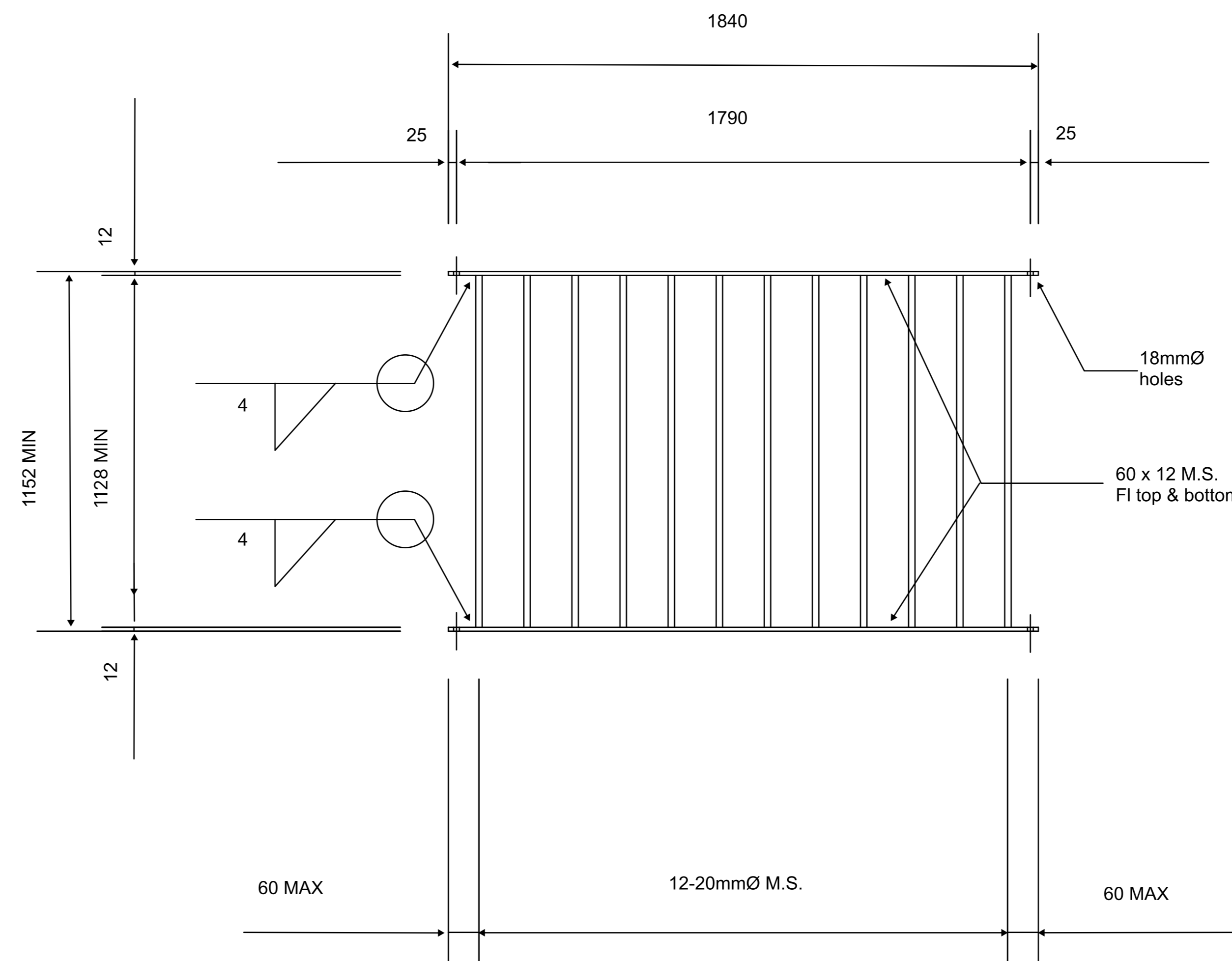

PANEL DETAIL

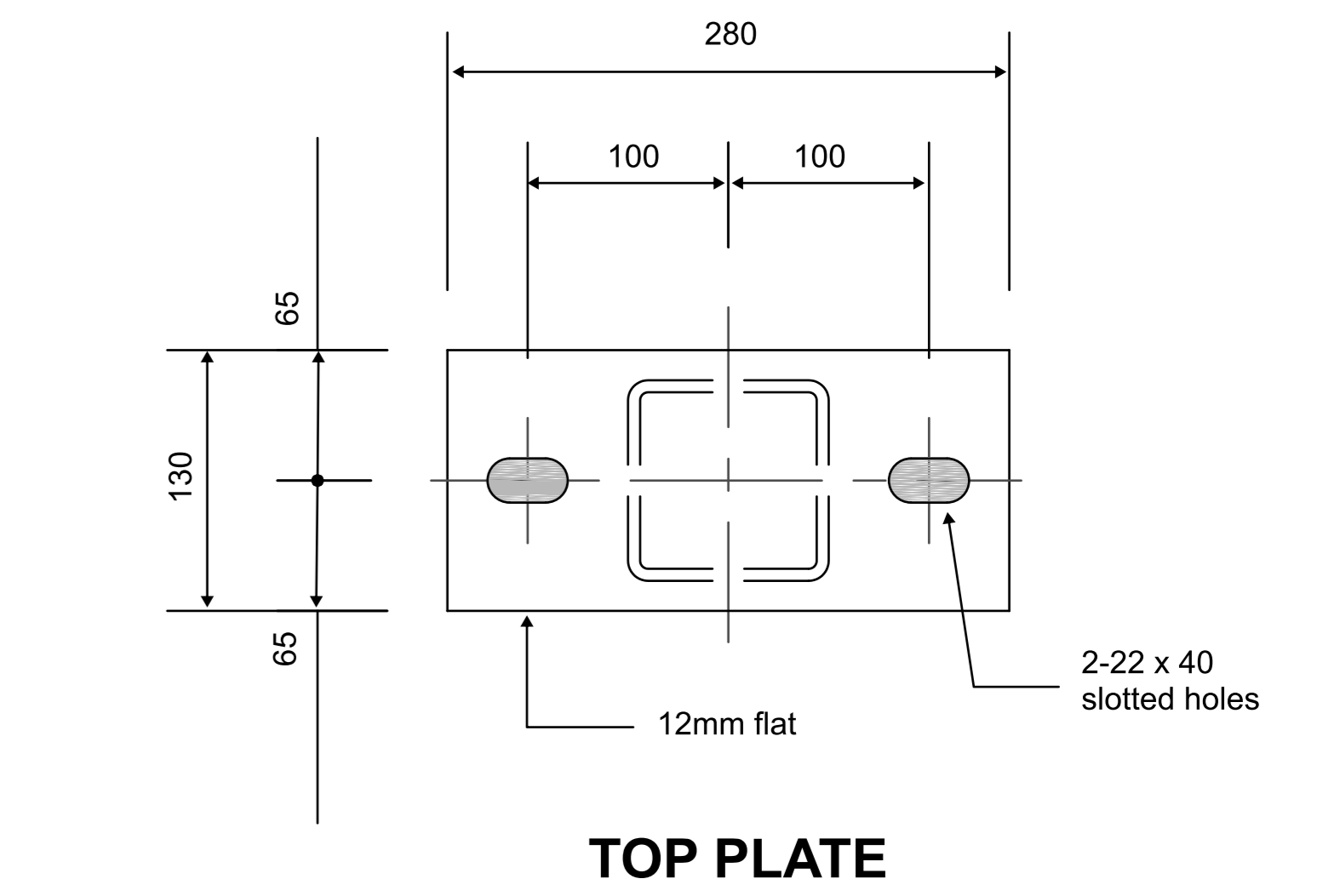

TOP PLATE

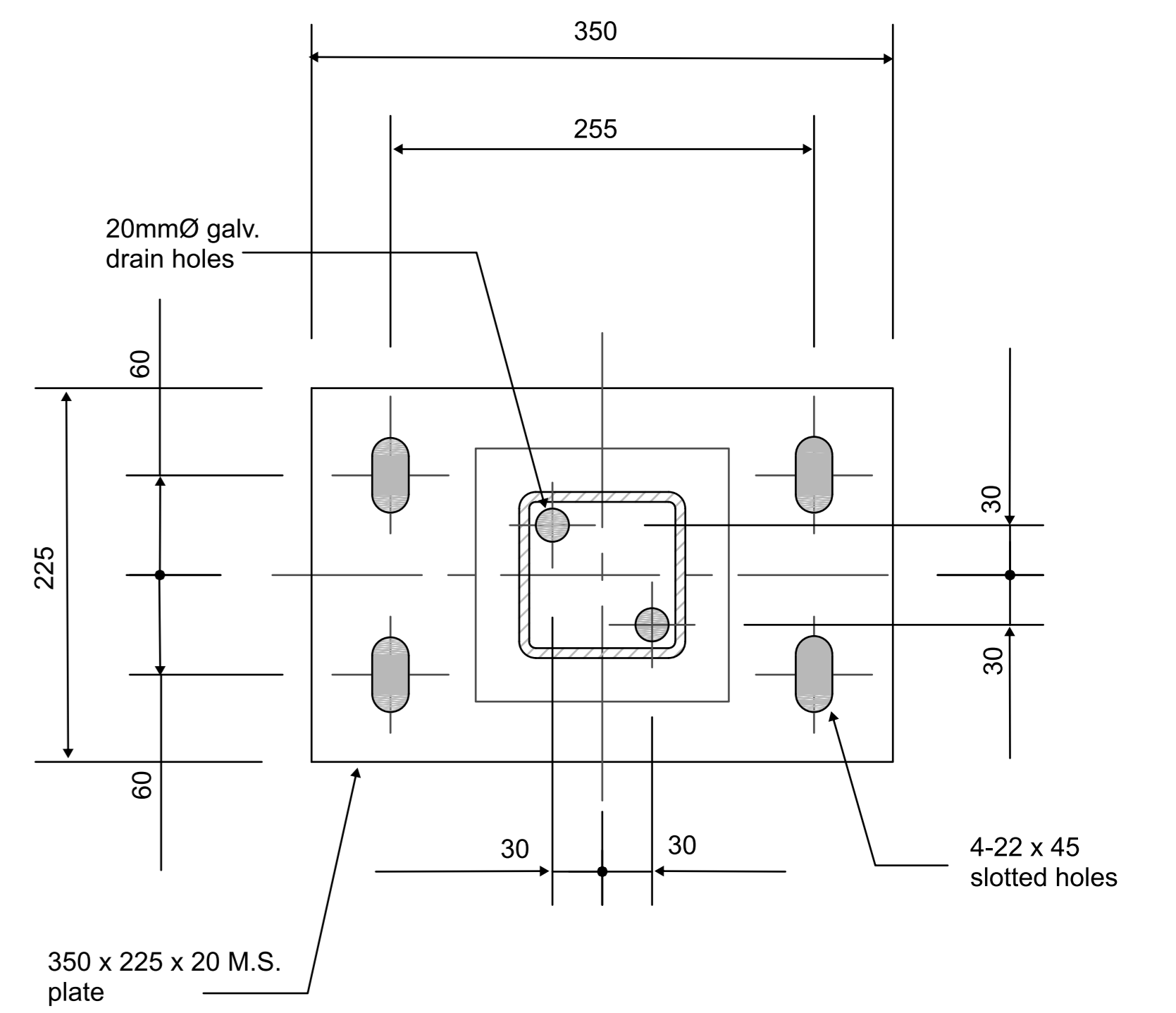

END POST PLATE

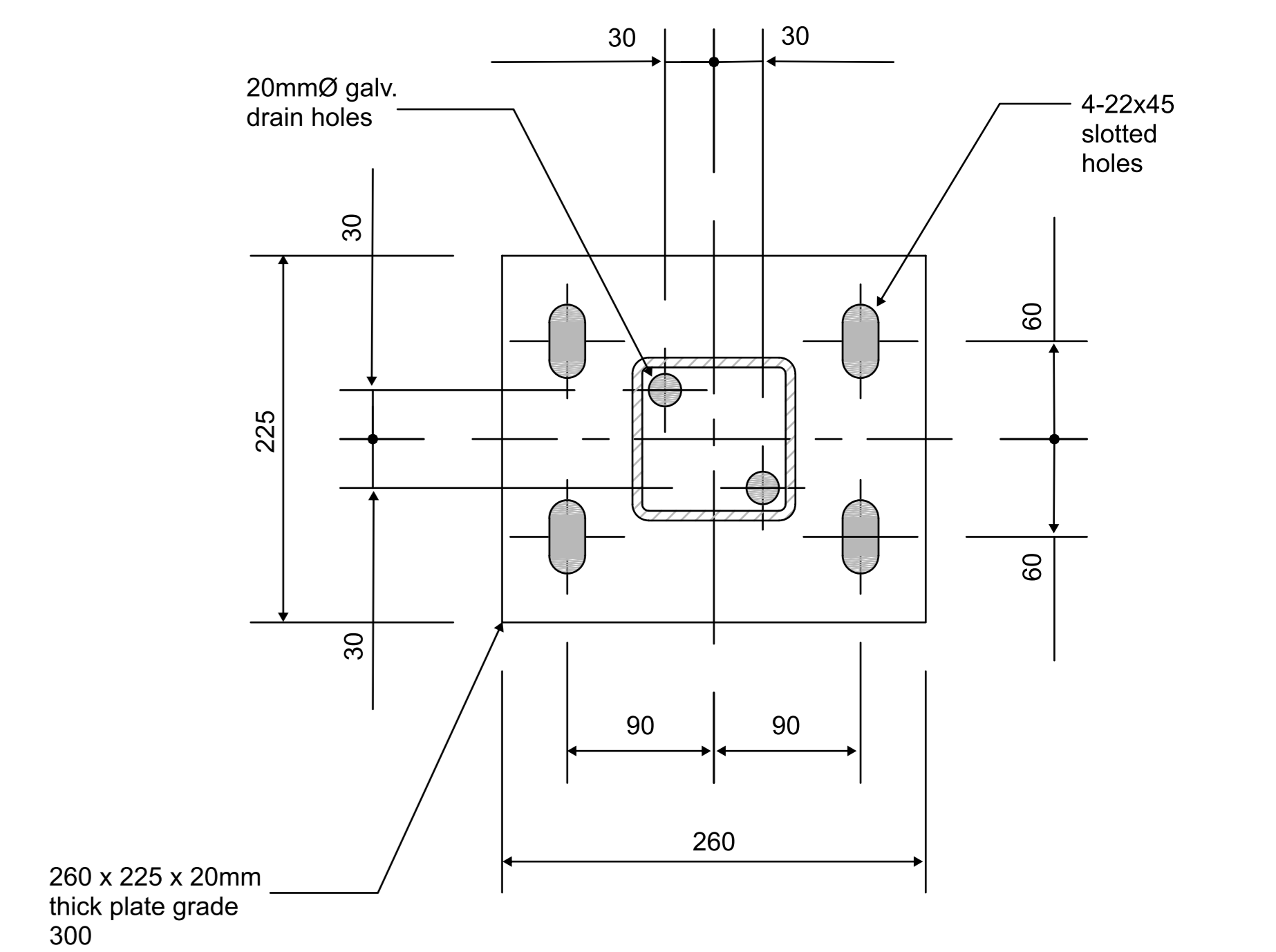

BASE PLATE



32E Forge Road, Silverdale, Auckland 0932
AKL: +64 9 421 1533
sales@thegategroup.co.nz
<https://thegategroup.co.nz>

MODEL:
TYPE F FENCE

ADDITIONAL INFORMATION & PRICING:
<https://thegategroup.co.nz/infrastructure>

DATE:
18 Feb 2025

REVISION:
V1.01

SPECIFICATION:
MATERIAL: NZ Sourced Steel
FINISH: Hot Dip Galvanised to AS/NZS4680
FIXINGS: Galvanised steel bolts

SIZE:
A4 DO NOT SCALE FROM DRAWING

DIMENSIONS:
Unless stated otherwise all dimensions are in mm